

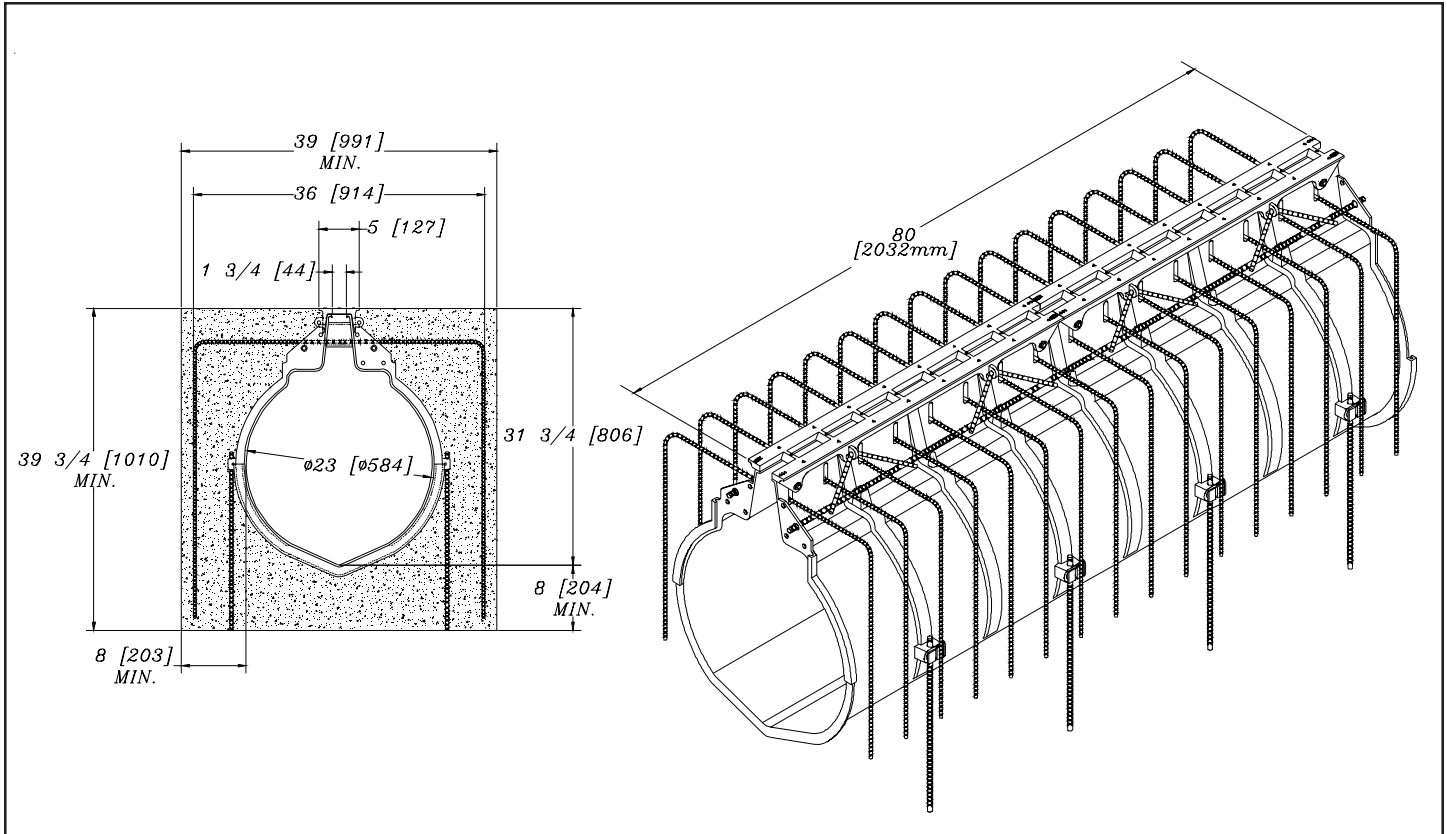

Z-888-36-DYN HI-CAP SLOTTED DRAINAGE SYSTEM



ENGINEERING SPECIFICATION

Zurn Z-888-36-DYN 23" wide 1 3/4" Hi-Cap slotted drainage system. Linear low density polyethylene modular drain channel with smooth non-stick, non-corrosive interior and 0% water absorption. 80" modular sections with integral frame, mechanically interlocking joints and smooth radiused interior. Integral tie-down/leveling devices at 20" intervals, U-shaped tensile strength rebar (#4 @8.5' long each) at 5" intervals, 4,000 psi concrete encasement (7.5 cubic foot /linear foot), and load distribution rebar stances with continuous lengths of rebar (#4) for structural integrity. **(Rebar, wire, and 4,000 psi concrete to be supplied by other.)**

PREFIX OPTIONS

Z*- 80" linear low density polyethylene modular drain channel with integral top frame.

FRAME OPTIONS (must choose one)

- ___ -DGF Ductile Iron Galvanized Frame
- ___ -DF Ductile Iron Black Dura Coated Frame
- ___ -FK Vertical Side Inlet Top Frame Flo-Kerb
- ___ -HPD Heelproof Ductile Iron Grate
- ___ -HPG Heelproof Ductile Iron Galvanized frame/grate
- ___ -HPS Heelproof Cast Stainless frame/grate
- ___ -PSF Pre-sloped Frame(slope _____, and length of run _____)
- ___ -SF Cast Stainless Frame

SUFFIX OPTIONS

- ___ -E1 End Cap
- ___ -E8 8" No Hub End Outlet
- ___ -E12 12" No Hub End Outlet
- ___ -E18 18" No Hub End Outlet
- ___ -E24 24" No Hub End Outlet
- ___ -E36 36" No-Hub End Outlet
- ___ -T18/36 Transition from -18 to -36

Supplied By:

**TRENCHDRAIN
SUPPLY**

877-903-7246

www.trenchdrainsupply.com

REV. B DATE: 12/16/03 C.N. NO. 101127

DWG. NO. 64092 PRODUCT NO. Z-888-36-DYN

*Regularly Furnished Unless Otherwise Specified

ZURN INDUSTRIES, INC., FLO-THRU DIV., 2640 South Work Street, Falconer, NY 14733

Phone: 716/665-1132, Fax: 716/665-1135, World Wide Web: www.zurn.com

In Canada: ZURN INDUSTRIES LIMITED, 3544 Nashua Drive, Mississauga, Ontario L4V1L2, Phone: 905/405-8272 Fax: 905/405-1292

In UK: Zurn Industries Ltd, Riverside Rd, Pottington Business Park, Barnstaple, Devon EX31 1QN, Phone 01271-340350 Fax 01271-344660